

# VT 1000 PTZL HD EX

## camera system

### brochure



## VT 1000 PTZL HD EX

### FullHD Ex classified inspection camera

**ATEX zone 1 rated & watertight FullHD camera with integrated dimmable lighting, pan and tilt function, with slipping clutch and zoom function**

#### Features

- ▶ ATEX certification (EX II 2G Ex eb ib pxb IIC T6 Gb)
- ▶ IECEx certification (EX eb ib pxb IIC T6 Gb)
- ▶ Robust design in stainless steel
- ▶ Pan & tilt including slipping clutch
- ▶ Zoom lens 30x optical / 12x digital
- ▶ 1080i/60 fps Full-HD resolution
- ▶ Integrated LED lighting and 2 line lasers
- ▶ Watertight up to 6 m

#### Applications

- ▶ Tank inspections in the oil & gas, chemical and petrochemical industries
- ▶ All visual inspections and monitoring in hazardous areas
- ▶ Industrial applications

# Technical specifications – VT 1000 PTZL HD EX camera

This document is for general information only,  
please consult the system manual for detailed specifications

ATEX zone	1
ATEX certification	EX II 2G Ex eb ib pxb IIC T6 Gb
IECEc certification	EX eb ib pxb IIC T6 Gb
Housing	stainless steel
Image sensor / number of effective pixels	CMOS / 2130k pixels
Output pixels (HxV)	1920x1080
Signal system	1080i/60
Minimum illumination	0.01 lx
Optical zoom	30x
Digital zoom	12x
Focus	automatic or manual
FOV	63.7° (wide) to 2.3° (tele)
Minimum object distance	10 mm (wide) to 1200 mm (tele)
Video output	Y/Pb/Pr
Range - PAN	infinite
Range - TILT	220° (± 110°)
Lighting	4x LED spots
Luminous flux	---
Dimension (LxWxØ)	250x117x135 mm
Weight	5 kg
Operating temperature	+1°C to +50°C
Water tight / water depth	0.6 bar / 6 m
Radiation tolerant	---
Total dose	---
Optionals	---
Features	integrated slipping clutch for pan & tilt, two line lasers stainless steel

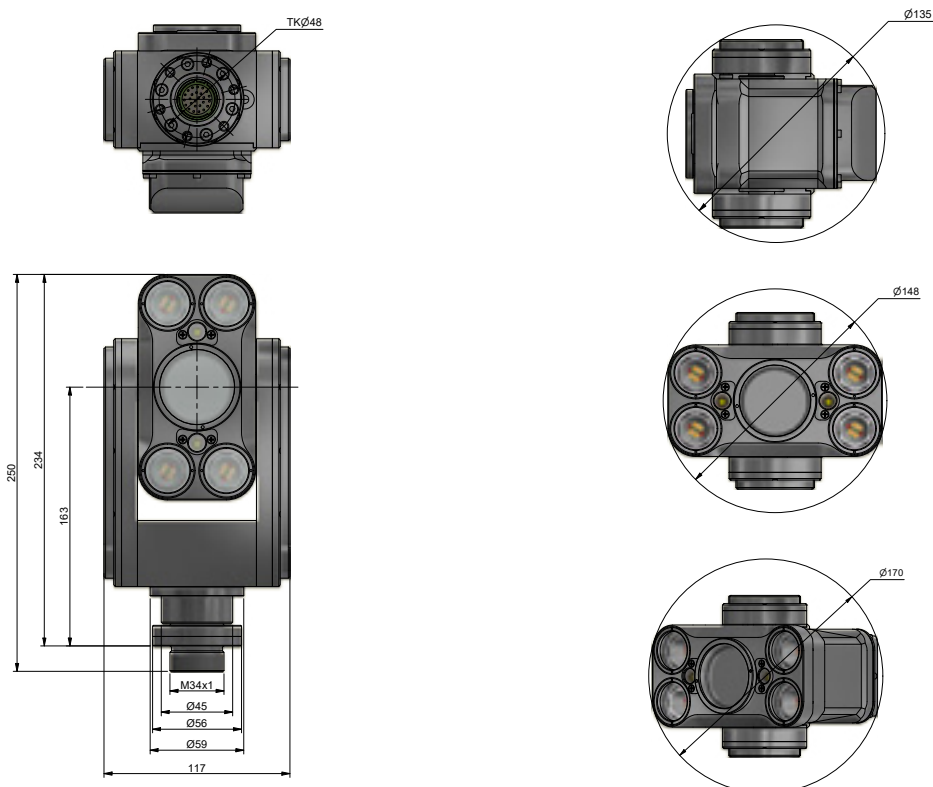

# Setup

## Possible combinations

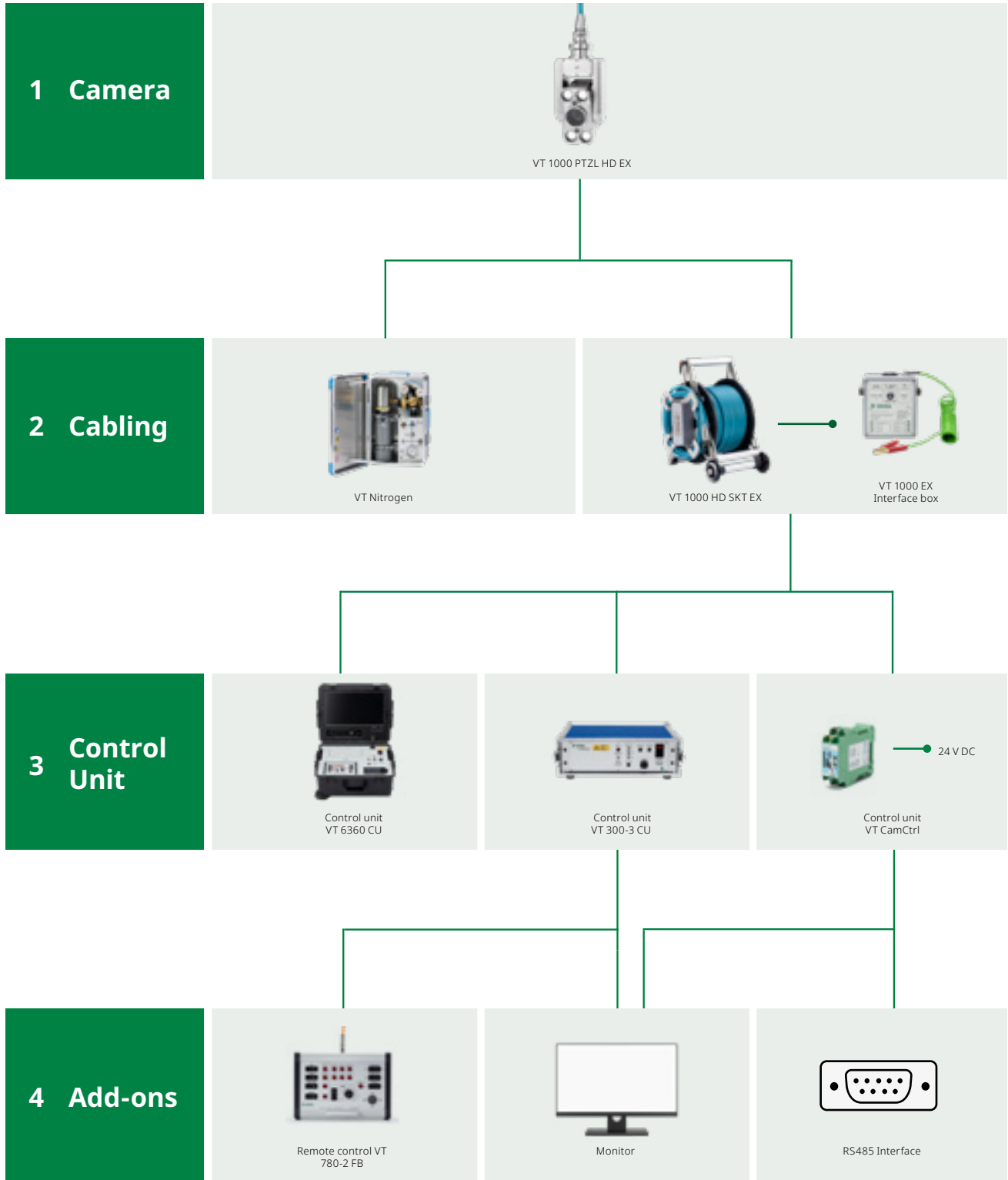

## Optional accessories - not ATEX / EX classified



### **VT 29 carbon poles - 29 or 42 mm diameter**

Connectable carbon poles for deployment of cameras and tools - standard lengths are 1 and 2 m



### **Manhole holder**

Versatile positioner for 29 or 42 mm carbon poles

## **DEKRA Visatec GmbH**

Gewerbepark 7  
87477 Sulzberg/See Germany  
Tel. + 49.8376.9215 0  
info.dvg@dekra.com

[dekra-visatec.com](http://dekra-visatec.com)