

# VT XLRAD-10 PTZ camera system brochure



## VT XLRAD-10 PTZ high radiation resistant inspection camera

**High radiation resistant & watertight tube camera with integrated dimmable lighting, pan and tilt function, with slipping clutch and zoom function**

### Features

- ▶ Robust design in anodized aluminum
- ▶ Pan & tilt including slipping clutch
- ▶ High radiation resistant
- ▶ Zoom lens 10x optical
- ▶ Pal signal system
- ▶ Integrated LED lighting
- ▶ Watertight up to 50 m

### Applications

- ▶ Nuclear applications - e.g. reactor inspection
- ▶ Decommissioning applications - e.g. pipe- and tank inspections, reactor inspection / hot cells
- ▶ All underwater inspections and monitoring applications in hard to reach areas

# Technical specifications – VT XLRAD-10 PTZ camera system

This document is for general information only,  
please consult the system manual for detailed specifications

Housing	anodized aluminum
Image sensor / number of effective pixels	Vidicon pic-up tube 2/3"
Horizontal resolution	> 460 TV lines
Signal system	PAL (without bust, monochrom)
Light sensitivity	5 Lux
Optical zoom	10x
Digital zoom	n/a
Focus	manual (motorized)
FOV	---
Minimum object distance	50 mm (depending on system configuration)
Video output	VBS
Range - PAN	infinite
Range - TILT	300° (± 150°)
Lighting	4x LED spots
Luminous flux	~ 6,000 lm
Dimension (ø x L)	302x131x149 mm
Weight	--- kg
Operating temperature	---
Water tight / water depth	5 bar / 50 m
Radiation tolerant	500,000 rad/h (5,000 Gy/h)
Total dose	110 Mrad (1.1 MGy)
Optionals	---
Features	integrated slipping clutch for pan & tilt

\* unit in mm

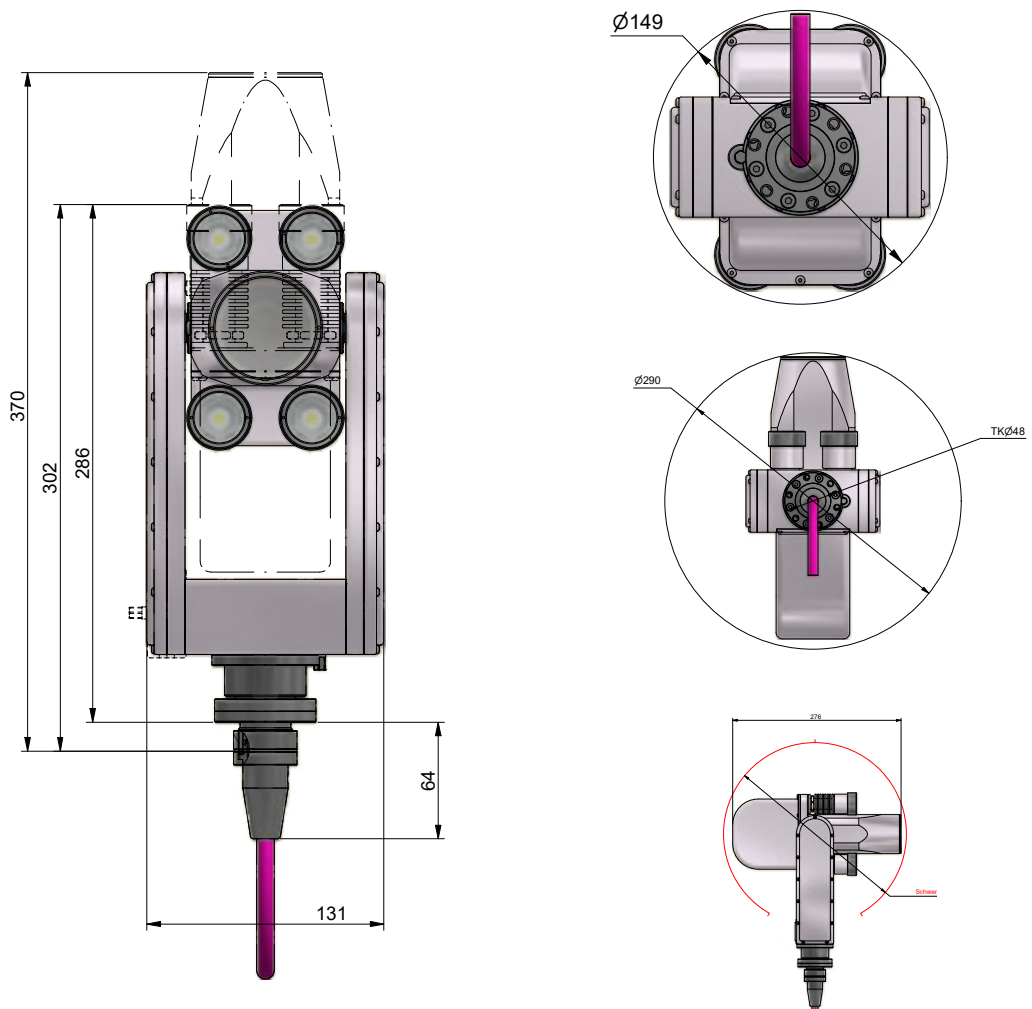

# Setup

## Possible combinations

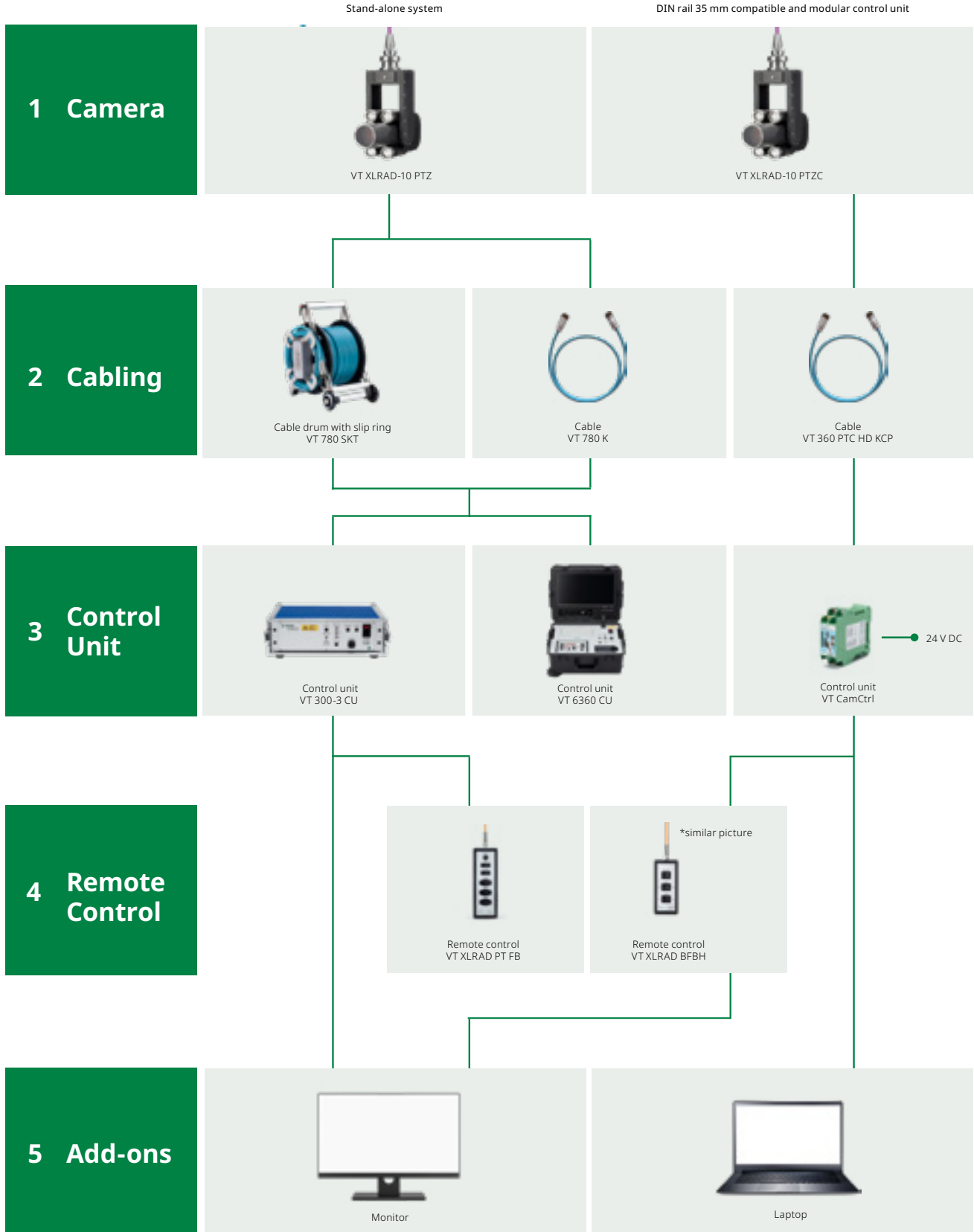

## Optional accessories - not ATEX / EX classified

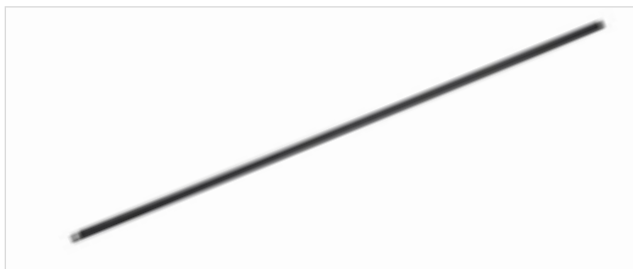

### VT 29 carbon poles - 29 or 42 mm diameter

Connectable carbon poles for deployment of cameras and tools - standard lengths are 1 and 2 m



### Manhole holder

Versatile positioner for 29 or 42 mm carbon poles



### VT 72 holder

Holder for mounting the camera with VT 29 GR carbon rods



### VT GH Vario tool holder

Variable railing bracket with stainless steel adapter for connecting the camera to 29 or 42 mm diameter carbon poles

## DEKRA Visatec GmbH

Gewerbepark 7  
87477 Sulzberg/See Germany  
Tel. + 49.8376.9215 0  
info.dvg@dekra.com

[dekra-visatec.com](http://dekra-visatec.com)