

Mechanized Testing Nuclear



Full vessel inspection from ID

DEKRA Industrial – Mechanized Testing has developed a manipulator for the inspection of the RPV Shell Welds and Core Shroud from the inside of the reactor.

This magnetic adhered and belt driven manipulator operates on ferritic pressure vessels with cladded inner surfaces, thickness of cladding up to 10 mm is possible. The manipulator is designed to operate in narrow gaps and can be maneuvered to any position on a cylindrical surface. With the unique design an accurate position can be established by the “on board” laser reference beam which gives a very precise position in both horizontal and vertical direction in relation to known internal objects. The exact position is sustained by inclinometer, immersion UT transducers and resolvers.

The manipulator Ringhorne can be configured for vertical scanning strokes with steps in the circumferential direction, or configured for circumferential scan strokes and vertical steps.

This makes it possible to perform scans optimized for longitudinal or transverse defects for both circumferential and vertical welds.

DEKRA cover all needs for development of manipulators and NDT, as well as probe design. The inspection system has successfully been tested and qualified according to ENIQ requirements at our test facility before the first outage performance.

Excellent customer response has been achieved after the performed inspection.



Ringhorne - ID inspection of vessels

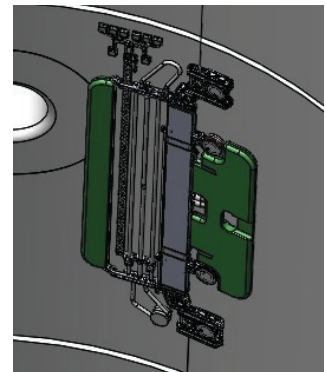
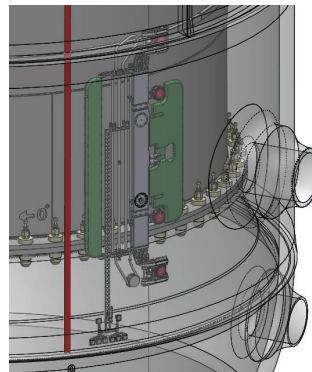

DEKRA Industrial AB
Sweden
+46 (0)10 - 455 1000
www.dekra-industrial.se

With reservations for errors and changes.

DEKRA - Global partner for a safe world

DEKRA is working for increased safety in a variety of industries through independent inspection, testing and certification. DEKRA is Europe's leading expert organization with 44 000 employees in 60 countries.